

LB Lever Hoists



MODEL: LB015

Setting new standards for the industry

Harrington's LB lever hoists have been completely redesigned to provide the operator with all of the features needed in one hoist. Our best just got better. As the leader in this hoist market, we studied the needs of the many industries using our lever hoists and then designed all of these important features into our new model. For your day-to-day maintenance and service work or the heavy-duty construction jobs, the Harrington LB lever hoist is always the right choice.

Look for the advantages

- Improved design
- Compact size
- Lighter weight
- Lower headroom
- Easy to operate, transport and store
- Trouble-free maintenance

Dependability

- Heavy duty all-steel construction
- Weston-style mechanical load brake
- Spring loaded free wheel mechanism
- Nickel plated corrosion-resistant load chain

Capacity Range

3/4, 1, 1-1/2, 2, 3, 6 and 9 Ton
Plus the Industry's first 2-3/4 Ton

Applications

- Maintenance and repairs
- Construction, mining and manufacturing
- Shipbuilding

Ask your local sales representative or call our Customer Service staff for friendly and expert advice on models and options.

LB LEVER HOISTS—SPECIFICATIONS AND DIMENSIONS

Cap. (Tons)	Product Code	Headroom C (in)	Std. Lift (ft)	Pull to Lift Load* (lbs)	a (in)	b (in)	D* (in)	e (in)	f (in)	g (in)	Load Chain Dia. (mm) x Chain Fall Lines	Net Weight (lbs)	Shipping Weight Approx. (lbs)	Weight for Additional One Foot of Lift (lbs)
3/4	LB008	11.0	5	54 (36)	5.7	4.7	9.6 (14.4)	3.8	1.6	0.9	5.6 x 1	13	13	0.5
1	LB010	11.8		72 (46)										
1 1/2	LB015	13.2		64 (45)	6.3	5.0		3.9	1.5	1.3	7.1 x 1	18	18	0.7
2	LB020	14.8		59 (42)	6.8	5.9	10.4 (14.4)	4.0	1.8	1.4	8.8 x 1	25	26	1.1
2 3/4	LB028			81 (57)										
3	LB030	15.6		69	6.3	5.0		16.3 (16.9)	4.4	2.3	2.0	10.0 x 1	33	35
6	LB060	21.3		72	7.5	8.5	4.4	2.3	2.0	10.0 x 2	57	60	3.2	
9	LB090	26.8		78	12.0	12.0	4.1	2.9	2.9	10.0 x 3	88	93	4.7	

*Figures in parentheses are for hoists with the optional load limit warning handle.

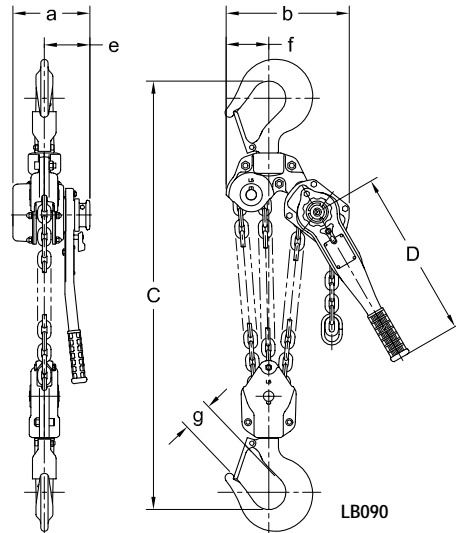
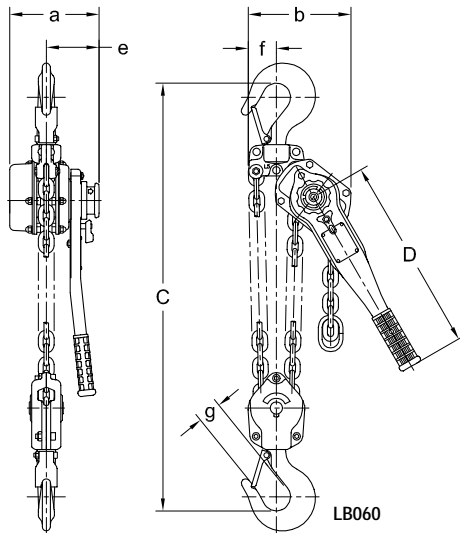
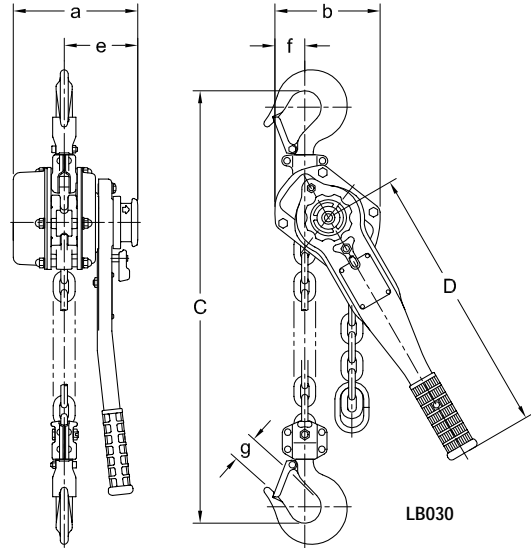
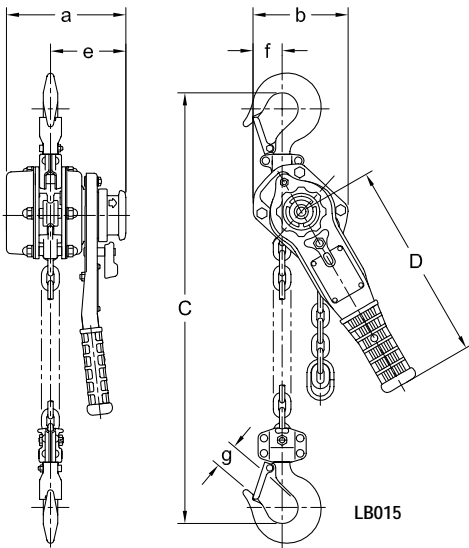



MODEL: LB008



MODEL: LB030



MODEL: LB060



MODEL: LB090

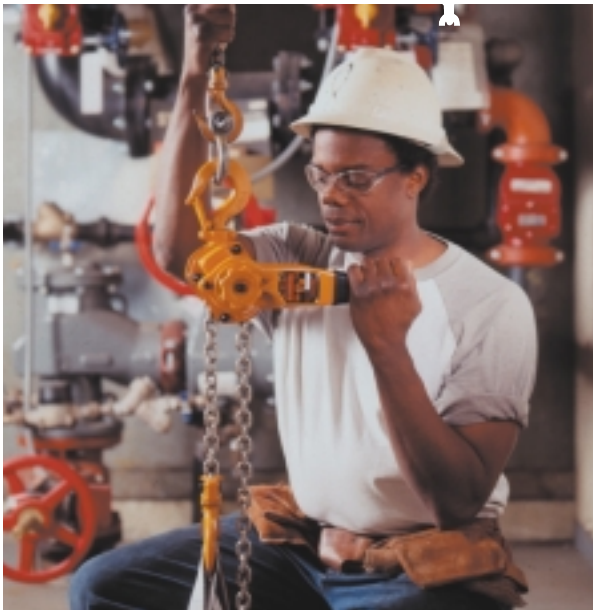

Easy to operate — improved design



Easy to transport — compact and lightweight

LB LEVER HOISTS—NEW CAPACITY

We now have capacity choices to fit every application. When 3 Ton is too much and 2 Ton is not enough, make the smart choice with Harrington's new...

- 2-3/4 Ton capacity
- Unique to the industry
- 10.4" handle length
- Compact and lightweight



MODEL: LB028

LB LEVER HOISTS—OPTIONAL ACCESSORIES



Point Load or Shipyard Hooks



Load Limit Warning Handle



Top Hook Extender

Consult Customer Service for full details.



Harrington Hoists, Inc.
401 West End Avenue, Manheim, PA 17545
717-665-2000 / 800-233-3010 / Fax: 717-665-2861
www.harringtonhoists.com

Harrington Hoists, Inc.—Western Division
2341 Pomona Rincon Road, No. 103
Corona, CA 92880-6973
951-279-7100 / 800-317-7111 / Fax: 951-279-7500

Specifications and dimensions are
subject to change without notice.
Rev 1 Copyright © 2003 1-05
Item No. SS-LB